

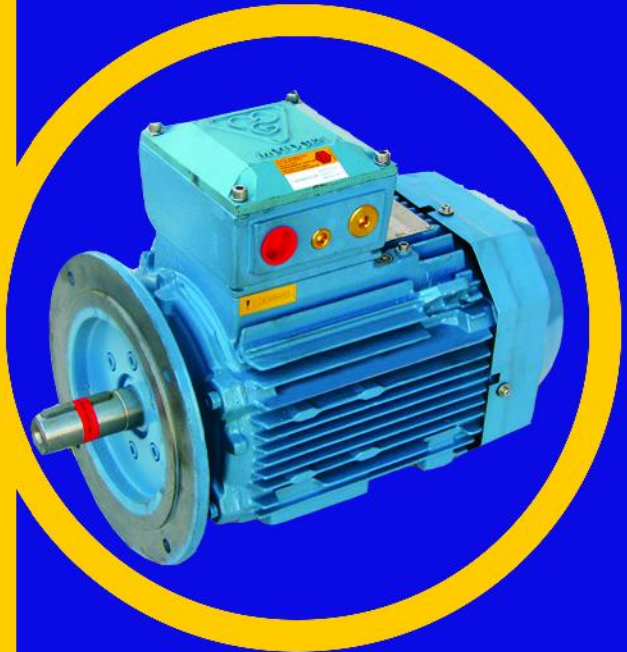

الکتروموتورهای ضدانفجار  
با دانش فنی ABB



Manufacturer of Flameproof  
Electromotors  
with ABB Technology



# مشخصات ابعادی الکتروموتورهای ضد انفجاری سایز فریم ۸۰-۱۳۲

## Dimensional specification of Flameproof electromotors frame size 80-132

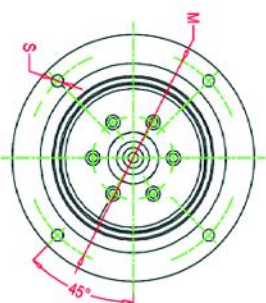
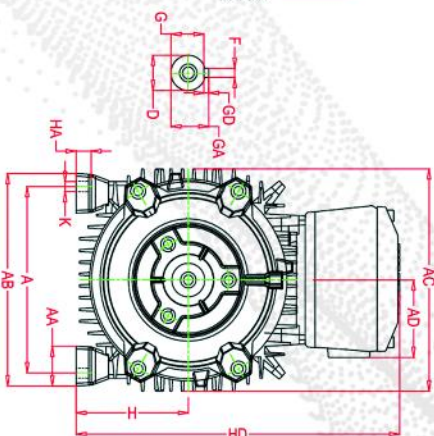
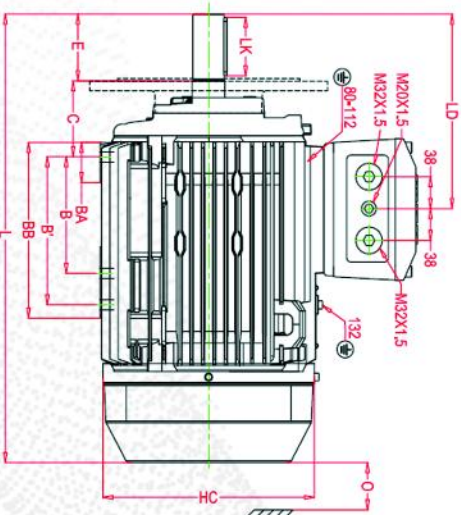
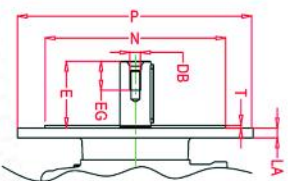

EEx d 80-132

Terminal box dimensions

EEx de 80-132

Motor size	AI	BI	HI
EEx d 80-132	175	170	115
EEx de 80-132	210	188	63

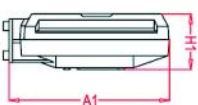
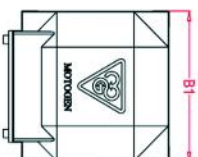
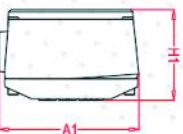
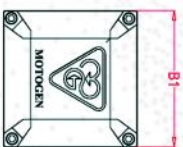

### Motor size Flange dimensions

Motor size	P	M	N	S
80-90	200	165	130	M10
100-112	250	215	180	M12
132	300	265	230	M12

### Cable glands sizes اندازه های گانده کابل

Frame size	Metric threads
80-90	1×M20×1.5+1×M25×1.5
100-132	1×M20×1.5+2×M32×1.5

Motor size	Poles	A	AA	AB	AC	AD	B	B'	BA	BB	C	D	DB	E	EG	F	G	GA	GD	H	HA	HC	HD	K	L	LD	O	LK
80M...	2-8	125	34	160	175	92	100	125	32	150	50	19	M6	40	16	6	15.5	21.5	6	80	10	160	300	10	340	170	20	32
90SL...	2-8	140	34	175	195	92	100	125	32	150	56	24	M8	50	19	8	20	27	7	90	10	190	315	10	405	180	20	40
100 L...	2-8	160	45	220	215	92	140	-	41	170	63	28	M10	60	22	8	24	31	7	100	10	210	335	12	440	194	25	50
112 M...	2-8	190	45	220	215	92	140	-	39	170	70	28	M10	60	22	8	24	31	7	112	15	210	350	12	440	194	25	50
132 SM...	2-8	216	44	245	275	92	140	178	48	210	89	38	M12	80	28	10	33	41	8	132	17	265	390	12	540	234	30	70



## مشخصات فنی الکتروموتورهای ضدانفجاری سایز ۸۰-۱۳۲

### Technical data of flameproof electromotors frame size 80-132

LV Flameproof three phase electromotors (LV Flameproof motors EEx d / EEx de IIC T4) in compliance with IEC, squirrel cage rotor IP 55 , duty cycle (s1) , method of cooling IC 411, insulation class F, temperature rise class B

الکتروموتورهای سه فاز ضدانفجار نوع (LV Flameproof motors EEx d / EEx de IIC T4) مطابق استاندارد IEC ، روتور قفس سنجایی ، درجه حفاظت IP55 ، مناسب برای کار دائم، روش تهویه IC411 (با پروانه خنک کننده و پره های روتور) کلاس حرارتی F ، افزایش دمایی کلاس B

Motor type	Frame size	Output power (KW)		Voltage (V)	Speed r/min	Efficiency (%)	Power factor cosφ	Current		Torque			Moment of inertia (Kgm)	Weight (kg)		Sound pressure level Lp dB(A)
		قدرت خروجی KW	400V,50HZ					440V,50HZ	I <sub>N</sub> (A)	I <sub>s</sub> / I <sub>N</sub>	T <sub>N</sub> (Nm)	T <sub>s</sub> / T <sub>N</sub>		T <sub>max</sub> / T <sub>N</sub>	EEx d	
3000 r/min = 2 Poles																
EEx d/de 80 MA2	80 M	0.75	0.9	230Δ/400Y	2861	77.2	0.86	1.62 Y	7.3	2.5	3.7	3.8	0.0006	37	28	59
EEx d/de 80 MB2	80 M	1.1	1.3	230Δ/400Y	2831	81.1	0.89	2.21 Y	5.7	3.7	3.0	3.2	0.0007	39	30	59
EEx d/de 90 SLA2	90 SL	1.5	1.75	230Δ/400Y	2881	81.9	0.88	3.0Y	6.7	5	3.0	3.5	0.001	50	41	65
EEx d/de 90 SLC2	90 SL	2.2	2.5	230Δ/400Y	2871	84.6	0.90	4.19 Y	7.5	7.3	2.7	3.5	0.0014	53	44	65
EEx d/de 100LA2	112 M	3	3.5	400Δ/690Y	2899	85.9	0.91	5.5Δ	7.5	10	2.2	3.0	0.0036	67	58	65
EEx d/de 112 MB2	112 M	4	4.6	400Δ/690Y	2901	87.1	0.90	7.5Δ	7.2	13	3.6	3.7	0.0043	70	61	65
EEx d/de 132 SMB2	132 SM	5.5	6.3	400Δ/690Y	2905	87.0	0.90	10.4Δ	6.7	18	2.4	3.3	0.009	98	89	71
EEx d/de 132 SMD2	132 SM	7.5	8.6	400Δ/690Y	2914	88.5	0.90	13.8Δ	7.6	25	2.8	3.6	0.012	106	97	71
1500 r/min = 4 Poles																
EEx d/de 80 MA4	80 M	0.55	0.65	230Δ/400Y	1421	76.1	0.75	1.4 Y	4.9	3.7	2.3	2.7	0.001	38	29	59
EEx d/de 80 MB4	80 M	0.75	0.9	230Δ/400Y	1413	77.3	0.78	1.8 Y	5.1	5.1	2.4	2.7	0.0012	38	29	59
EEx d/de 90 SLA4	90 SL	1.1	1.3	230Δ/400Y	1435	79.9	0.80	2.48Y	6.7	7.3	2.8	3.5	0.002	51	42	54
EEx d/de 90 SLC4	90 SL	1.5	1.75	230Δ/400Y	1431	80.9	0.81	3.31Y	6.5	10	2.9	3.4	0.003	53	44	54
EEx d/de 100 LA4	112 M	2.2	2.5	230Δ/400Y	1441	85.8	0.86	4.4Y	7	14.5	2.7	3.3	0.0075	67	58	52
EEx d/de 100 LB4	112 M	3	3.5	400Δ/690Y	1442	85.5	0.83	6.1Δ	7	20	2.7	3.4	0.0081	69	60	52
EEx d/de 112 MC4	112 M	4	4.6	400Δ/690Y	1436	85.0	0.81	8.4Δ	6.9	27	2.9	3.7	0.0093	72	63	52
EEx d/de 132 SMB4	132 SM	5.5	6.3	400Δ/690Y	1448	87.0	0.80	11.4Δ	6.7	36	3.1	3.3	0.02	102	93	60
EEx d/de 132 SMD4	132 SM	7.5	8.6	400Δ/690Y	1447	87.9	0.80	15.4Δ	6.6	50	3.1	3.4	0.023	108	99	60
1000 r/min = 6 Poles																
EEx d/de 80 MA6	80 M	0.37	0.45	230Δ/400Y	957	72.2	0.60	1.22Y	5	3.7	3.4	3.6	0.0022	38	29	55
EEx d/de 80 MB6	80 M	0.55	0.65	230Δ/400Y	942	72.7	0.66	1.66Y	4.5	5.6	2.8	2.9	0.0022	38	29	55
EEx d/de 90 SLA6	90 SL	0.75	0.9	230Δ/400Y	942	72.8	0.68	2.17Y	4.5	7.6	2.8	3.2	0.0036	50	41	44
EEx d/de 90 SLC6	90 SL	1.1	1.3	230Δ/400Y	940	74.4	0.66	3.25Y	4.6	11	3.1	3.4	0.0037	52	43	44
EEx d/de 100 LA6	112 M	1.5	1.75	230Δ/400Y	956	80.3	0.74	3.6Y	4.9	15	2.3	2.9	0.012	66	57	47
EEx d/de 112 MB6	112 M	2.2	2.5	230Δ/400Y	950	80.9	0.75	5.2Y	4.8	22	2.2	2.8	0.014	69	60	50
EEx d/de 132 SMB6	132 SM	3	3.5	400Δ/690Y	961	82.4	0.76	6.9Δ	6.1	30	2.1	3.0	0.032	102	93	57
EEx d/de 132 SMC6	132 SM	4	4.6	400Δ/690Y	967	84.9	0.73	9.3Δ	6.6	39.5	2.3	3.4	0.034	104	95	57
EEx d/de 132 SMD6	132 SM	5.5	6.3	400Δ/690Y	958	84.8	0.75	12.5Δ	6.7	55	2.2	3.0	0.036	106	97	57
750 r/min = 8 Poles																
EEx d/de 80 MA8	80 M	0.18	0.22	230Δ/400Y	720	51.8	0.46	1.08Y	3.2	2.4	3.7	4.0	0.0022	38	29	36
EEx d/de 80 MB8	80 M	0.25	0.3	230Δ/400Y	705	56.0	0.56	1.15Y	3.0	3.4	2.6	2.8	0.0022	38	29	36
EEx d/de 90 SLA8	90 SL	0.37	0.45	230Δ/400Y	696	63.6	0.62	1.34Y	3.0	5.1	2.0	2.2	0.0036	50	41	36
EEx d/de 90 SLC8	90 SL	0.55	0.65	230Δ/400Y	695	65.0	0.60	2.05Y	3.1	7.6	2.2	2.4	0.0037	52	43	36
EEx d/de 100 LA8	112 M	0.75	0.9	230Δ/400Y	720	73.5	0.57	2.6Y	3.8	10	2.0	2.9	0.012	66	57	44
EEx d/de 100 LB8	112 M	1.1	1.3	230Δ/400Y	717	74.0	0.55	3.9Y	3.7	15	2.1	2.9	0.012	66	57	46
EEx d/de 112 MC8	112 M	1.5	1.75	230Δ/400Y	713	75.6	0.57	5.0Y	3.7	20	2.0	2.7	0.014	70	61	44
EEx d/de 132 SMC8	132 SM	2.2	2.5	400Δ/690Y	720	78.6	0.64	6.3Δ	4.7	29	2.0	2.9	0.034	104	95	59
EEx d/de 132 SMD8	132 SM	3	3.5	400Δ/690Y	710	79.3	0.69	8.0Δ	4.1	40	1.7	2.3	0.036	106	97	59

Motors are certified for the voltages 380-400-415 V , 50 HZ according to IEC 60034-1. Values above are given for 400V,50Hz.

الکتروموتورها برای ولتاژهای 380-400-415 V و فرکانس 50Hz مطابق استاندارد IEC60034-1 در نظر گرفته شده اند ، مقادیر بالا برای ولتاژ 400V و فرکانس 50Hz داده شده است.

IP 56.65 as request

IP 56.65 بنا به سفارش



# MOTOGEN



## TECHNICAL SPECIFICATIONS

PARAMETERS	Value
Motor type	EExd 90SLC2
Frame size	90SL
Output power (KW)-400V/50Hz	2.2
Output power (KW)-440V/60Hz	2.5
Rated voltage (V)	230/400
Rated speed (RPM)	2871
Efficiency (%)	84.6
Power factor (Cos phi)	0.9
Rated current (A)	4.19Y
Starting current/Rated current	7.5
Rated torque (N m)	7.3
Starting torque/Rated torque	2.7
Breakdown torque/Rated torque	3.5
Moment of inertia (Kg*m <sup>2</sup> )	0.0014
Weight-EEx d (Kg)	53
Weight-EEx de (Kg)	
Sound pressure level (dB)	65
Color	Blue - RAL5024
Body	Cast Iron
Stator winding wire material	copper
Rotor winding material	aluminium
Driven end bearing	6201-2Z
Non-driven end bearing	6201-2Z